

# 样品承认书

## SPECIFICATIONS OF NICKEL METAL HYDRIDE BATTERY

客户代号(Customer P/N): 2020509

产品型号(Model Name): GMCELL-48AA1600mAh\*6

发行日期(Issued Date): 2022-02-10

确 认(APPROVED):

客户/Customer			
确 认/Checked By		编 制/Audited By	高旺/Mr. Gao wang
		确 认/Checked By	官洞山/ Mr. Guan dongshan
批 准/Approved By		批 准/Approved By	
签 章/Signature & chop		签 章/ Signature & chop	



## 圆柱密封式镍氢电池出厂规格报告 Specification for Cylindrical Sealed Nickel Metal Hydride Batteries

适用范围：本规格书只作为验货（收到货一个月内进行）标准，不作为存货检验标准

APPLICATION: The applicable range: This specification is available only for the testing within one month since receipt of batteries. It's not a standard for stored goods.

1产品型号/ Model: GMCELL-48AA1600mAh\*6

### 2. 额定参数/RATINGS:

◇ 额定电压/Nominal Voltage	<u>7.2 V</u>
◇ 额定容量/ Nominal	<u>1600mAh</u>
◇ 最小容量/ Minimum	<u>1550mAh/0.2C</u>
◇ 标准充电/Standard charge rate	<u>160mA×16hrs</u>
◇ 快速充电/ Rapid charge rate	<u>800mA×140min (-ΔV= 5mV/pcs)</u>
◇ 作用温度范围/ Operating temperature range	湿度/ Humidity: +65%± 20%
标准充电/Standard charge	0~40°C(32 to 104°F)
快速充电/ Rapid charge	10~35°C(50 to 95°F)
浮 充 电/ Floating charge	-10~40°C(14to 104°F)
放 电/ Discharge	-20~55°C(-4 to 131°F)
◇ 贮存温度范围/ Storage temperature range	湿度/Humidity : +65%±20%
长期贮存（1年内）/ Within 1 year	-20°C~35°C(-4 to 95°F)
6个月内 / Within 6 months	-20°C~45°C(-4 to 113°F)
1个月内 / Within 1 month	-20°C~50°C(-4 to 122°F)

备注：（1）所有的快速充电方法应与我们的工程师讨论；

All rapid charge methods should be discussed with our engineer.

（2）本公司规定电池的出货带电量≤50%，带电量超过 50%的情况下，电池具有一定的潜在危险性。对出货要求带电量超过 50%可能带来的质量问题，由双方共同协商后执行；

We stipulate to charge less than 50% fully power for delivery, if the charge is more than 50%, the battery has a certain latent risk. If the charge requirement is over 50% which caused quality problem, executed after the mutual consultation .

（3）批量电池在储存期间要求带 50%电量存放，电池在储存超过 3 个月时，建议 0.2C 清电后补充 50%的电量； / During storage period the batch battery is requested by the 50% electric charge, the battery storage surpasses 3 months, the recommendations 0.2C discharge to 6.0V and then add 50% of the electricity storage.

（4）电池保质期：12 个月。Our battery guarantee time: 12 months.

3. 尺寸及形状(单体)/Measurement & Dimensions(cell)

如图所示/ to see the drawing:

D	13.8-14.5mm
H	47.5-49.0mm
D1	8.0±0.2mm
H1	0.8±0.3mm

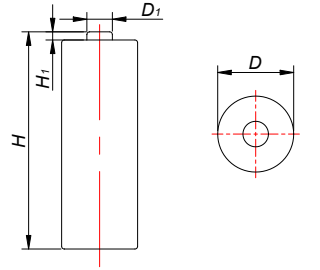

4. 测试/ Performance Testing

4.1 测试条件/ TEST CONDITIONS

4.1.1 测试电池为用户收到后不超过 1 个月的产品/The battery to be tested is the product within one month after being received by customer.

4.1.2 测试条件	Ambient conditions:
温度 20±5°C	Temperature +20°C±5°C
湿度 65±20%	Humidity +65%±20%

4.2 测试工具/ Testing Tools

4.2.1 电压计 IEC 51/IEC 485 所规定的 0.5 级或以上。内阻大于 10KΩ/V。

Voltage meter 0.5 level or higher as required in IEC51/IEC485. Internal impedance exceeds 10KΩ/V.

4.2.2 电流计 IEC 51/IEC 485 所规定的 0.5 级或以上。包括引线总电阻小于 0.01Ω。

Current meter 0.5 level or higher as required in IEC51/IEC485. Internal impedance should be less than 0.01Ω/V(including wires).

4.2.3 卡尺 读数值 0.02MM

Micrometer caliper With precision of 0.02mm.

4.2.4 内阻计 交流 1000HZ 正弦波 4 端子测量装置。

Internal impedance meter Alternating current of 1000HZ, connector measuring equipment with sin wave of 4.

4.2.5 负载电阻 包括外部线路,电阻值允许误差为±5%。

Impedance loaded meter Value of impedance is with ±5% error allowed (including external wires).

4.3 测试方法及基准/ Test methods and benchmarks

项目/ Item	试验方法/ Test Method	基准/ Benchmark
1. 外观、包装 Appearance	<ul style="list-style-type: none"> <li>◇ 肉眼测试</li> <li>◇ eyeballing</li> </ul>	<ul style="list-style-type: none"> <li>◇ 目测电池应无任何会减少其商业价值的缺陷，如污迹、变形、及划痕。</li> <li>◇ batteries shall be free from any stains; scratches or deformations, which may reduce the commercial value when visually inspected</li> </ul>

<p>2. 尺寸/ Size</p>	<ul style="list-style-type: none"> <li>◇ 卡尺测量。</li> <li>◇ caliper measurement</li> </ul>	<ul style="list-style-type: none"> <li>◇ 符合附图所示尺寸。</li> <li>◇ The size shall comply with the specified size as the attached drawing</li> </ul>
<p>3. 绝缘电阻 Insulate impedance</p>	<ul style="list-style-type: none"> <li>◇ 用兆欧表测量电池外包装及电极之间的绝缘度。</li> <li>◇ measured with a Megger overpack and battery electrode between the degree of insulation</li> </ul>	<ul style="list-style-type: none"> <li>◇ 大于 <u>10MΩ</u>。</li> <li>◇ outer sleeve shall exceed <u>10 MΩ</u></li> </ul>
<p>4. 重量/ Weight</p>	<ul style="list-style-type: none"> <li>◇ 用架盘天平测量。</li> <li>◇ using disk-scale measurement</li> </ul>	<ul style="list-style-type: none"> <li>◇ 约等于 <u>148g</u>。</li> <li>◇ approximate <u>148 g</u></li> </ul>
<p>5. 充电电压 Charge Voltage</p>	<ul style="list-style-type: none"> <li>◇ 将电池以 <u>0.2CmA</u> 电流放电到终止电压，然后进行标准充电，在充电结束前 5 分钟内测定电压。</li> <li>◇ Following a period of discharge at <u>0.2CmA</u> down to a terminal voltage of 6.0V, standard charge, the cell or battery shall be checked at 5 minutes before finish charging</li> </ul>	<ul style="list-style-type: none"> <li>◇ 小于 <u>9.6V</u>。</li> <li>◇ The voltage shall be less than <u>9.6 V</u></li> </ul>
<p>6. 开路电压 Open circuit voltage: (O.C.V.)</p>	<ul style="list-style-type: none"> <li>◇ 在标准充电结束后 1 小时内测定电池之开路电压。</li> <li>◇ Following a standard charge period, the open circuit voltage of the cell or battery shall be checked within 1 hour.</li> </ul>	<ul style="list-style-type: none"> <li>◇ 大于 <u>7.5V</u>。</li> <li>◇ The O.C.V. shall exceed<u>7.5 V</u></li> </ul>
<p>7. 闭路电压 Closed circuit voltage: (C.C.V.)</p>	<ul style="list-style-type: none"> <li>◇ 在标准充电结束后 1 小时内测定电池之闭路电压。负载电阻 <u>5.16Ω</u>。</li> <li>◇ Following a standard charge period, the closed circuit voltage of the cell or battery shall be checked with a <u>5.16 Ω</u> load within 1 hour</li> </ul>	<ul style="list-style-type: none"> <li>◇ 大于 <u>7.2V</u>。</li> <li>◇ The C.C.V. shall exceed <u>7.2 V</u></li> </ul>
<p>8. 内阻 Internal impedance</p>	<ul style="list-style-type: none"> <li>◇ 标准充电结束后 1 小时内测定电池的内阻。</li> <li>◇ Following a standard charge period, the internal impedance of the cell or battery shall be checked at 1000Hz within 1 hour</li> </ul>	<ul style="list-style-type: none"> <li>◇ 小于等于 <u>400 mΩ</u>。</li> <li>◇ The internal impedance shall not be more than <u>400 mΩ</u></li> </ul>
<p>9. 容量/ Capacity</p>	<ul style="list-style-type: none"> <li>◇ 标准充电结束后 1 小时以内将电池以 <u>0.2CmA</u> 放电至 6.0V 测定电池的容量；</li> <li>◇ Following a standard charge period, the cell shall be stored for a period of 1 hour. The capacity shall be equal or more than minimum capacity when discharged at <u>0.2C mA</u> down to a terminal voltage of 6.0V;</li> <li>◇ 第一次充放电之后，所得的容量值可能与标明的数值有出入，在这种情况下，应再重复测试两到三次以上，以达到标明数值。</li> </ul>	<ul style="list-style-type: none"> <li>◇ 大于等于最低容量。</li> <li>◇ The capacity is greater than or equal to the minimum capacity</li> </ul>

	<ul style="list-style-type: none"> <li>◇ The capacity returned might not initially attain the specified value following the first charge – discharge cycle. In this event, the test may be repeated a further two or three times to attain the minimum capacity</li> </ul>	
10. 大电流放电特性/High Drain Discharge	<ul style="list-style-type: none"> <li>◇ 标准充电结束后 1 小时以内以 <u>0.5C</u> 放电至 6.0V，测定放电时间。</li> <li>◇ To discharge by <u>0.5 C</u> to 6.0V within 1 hour after standard charge</li> </ul>	<ul style="list-style-type: none"> <li>◇ 大于等于 <u>108</u> 分钟。</li> <li>◇ The Capacity is higher than or equal to <u>108</u> min</li> </ul>
11. 自放电特性 Self discharge	<ul style="list-style-type: none"> <li>◇ 将电池以 <u>0.2CmA</u> 放电至 6.0V，然后标准充电常温放置 28 天，再以 <u>0.2CmA</u> 放电，测定剩余容量。</li> <li>◇ Following a period of discharge at <u>0.2C mA</u> down to a terminal voltage of 6.0V, standard charge and then the cell or battery shall be <b>stored for 28 days</b> below 20°C</li> </ul>	<ul style="list-style-type: none"> <li>◇ 大于等于额定容量的 <u>70%</u>。</li> <li>◇ The subsequent capacity shall not be less than <u>70%</u> of rated capacity when discharged at <u>0.2C mA</u></li> </ul>
12. 过充电特性 Over-charge	<ul style="list-style-type: none"> <li>◇ 将电池以 <u>0.2CmA</u> 放电至 6.0V，先标准充电，再以 <u>0.1CmA</u> 充电 48 小时后，以 <u>0.2CmA</u> 放电至 6.0V，测定电池容量。</li> <li>◇ Following a period of discharge at <u>0.2C mA</u> down to a terminal voltage of 6.0V, standard charge and then charge for 48hrs at <u>0.1C mA</u>. The capacity of the cell or battery shall not be less than the rated capacity when discharged at <u>0.2C mA</u></li> </ul>	<ul style="list-style-type: none"> <li>◇ 无外观变形，无漏液。</li> <li>◇ 容量大于等于额定容量。</li> <li>◇ It shall not be externally deformed and no leakage of electrolyte in liquid form shall be observed.</li> </ul>
13. 过放电特性 Over-discharge	<ul style="list-style-type: none"> <li>◇ 将电池以 <u>0.2CmA</u> 放电至 6.0V，然后将电池串联负载 <u>5.16Ω</u> 的内阻继续放电 24 小时，再将电池标准充电后以 <u>0.2CmA</u> 放电，测定电池的容量。</li> <li>◇ Following a period of discharge at <u>0.2C mA</u> down to a terminal voltage of 6.0V, combine the cells with a <u>5.16Ω</u> load. After stored for a period of 24 hours, standard charged and then discharge at <u>0.2C mA</u></li> </ul>	<ul style="list-style-type: none"> <li>◇ 无外形变形</li> <li>◇ 容量大于等于额定容量的 <u>80%</u>。</li> <li>◇ the cell or battery shall not be externally deformed and no leakage of electrolyte in liquid form shall be observed, and the subsequent capacity shall not be less than <u>80%</u> of rated capacity</li> </ul>
14. 循环寿命 Cycle Life	<ul style="list-style-type: none"> <li>◇ 按照 IEC61951-2(2017)实验方法(参照备注标准测试条件)。</li> <li>◇ Based on clause IEC61951-2(2017) (Reference standard test conditions)</li> </ul>	<ul style="list-style-type: none"> <li>◇ 循环寿命大于 <u>500</u> 次。</li> <li>◇ The charge-discharge cycles shall exceed <u>500</u> times</li> </ul>
15. 密封性测试 Humidity	<ul style="list-style-type: none"> <li>◇ 将电池标准充电后，在温度 33±3°C，湿度 80±5% 的环境中放置 14 天。</li> </ul>	<ul style="list-style-type: none"> <li>◇ 肉眼观察无漏液现象。</li> <li>◇ No leakage of electrolyte in</li> </ul>

	<ul style="list-style-type: none"> <li>◇ Standard charge and store for 14 days under the following storage conditions: 33°C±3°C(91.4°F±5.4°F) , Relative humidity of 80%±5%. (Salting is permitted).</li> </ul>	liquid form shall be observed
16. 耐振动性 Vibration	<ul style="list-style-type: none"> <li>◇ 将电池标准充电后放置 24 小时以上, 然后以下列条件使电池振动, 测定振动前后的特性变化。 振幅: 4MM 频率: 1000 次/分 时间、方向: 任意方向, 连续 60 分</li> <li>◇ Store the cell or battery more than 24 hours after standard charge, following vibration tests over an amplitude of 4 mm (0.1575 inches) at a frequency of 16.7 Hz(1000 cycles per minute) and repeated through any axes during 60mins</li> </ul>	<ul style="list-style-type: none"> <li>◇ 开路电压变化在 <u>0.12V</u> 以下, 内阻变动<u>30 mΩ</u>以下, 外观无明显变化。</li> <li>◇ The subsequent fluctuation of open circuit voltage and internal impedance shall be less than <u>0.12 V</u> and <u>30 mΩ</u> respectively, and the cell or battery shall not be externally deformed and no leakage of electrolyte in liquid form shall be observed.</li> </ul>
17. 耐撞击性能 Free falling: (Drop)	<ul style="list-style-type: none"> <li>◇ 将电池标准充电后放置 24 小时以上, 然后使电池垂直跌落, 测定跌落前后的特性变化。 跌落高度: 450mm 跌落面: 硬木板 跌落次数: 任意方向, 3 次</li> <li>◇ Store the cell or battery more than 24 hours after standard charge, following a drop test from 450mm on to a hard-wood board in a vertical axis 3 times on each of 2 mutually perpendicular axes</li> </ul>	<ul style="list-style-type: none"> <li>◇ 开路电压变化在 <u>0.12V</u> 以下, 内阻变动在<u>30 mΩ</u>以下, 外观无明显变化。</li> <li>◇ The subsequent fluctuation of open circuit voltage and internal impedance shall be less than <u>0.12 V</u> and <u>30 mΩ</u> respectively, and the cell or battery shall not be externally deformed and no leakage of electrolyte in liquid form shall be observed.</li> </ul>
18. 短路测试 Short-circuit testing	<ul style="list-style-type: none"> <li>◇ 将电池标准充电后, 放置 1 个小时, 然后用导线使正负极短路, 导线截面在 0.75mm<sup>2</sup> 以上, 导线长度为正负极间最短距, 短路时间 1 小时。</li> <li>◇ to store it for 1 hour after standard charged, and to make positive and negative electrode short-circuit with a wire with the section 0.75mm<sup>2</sup>min and shortest length, the short-circuit time is 1 hour</li> </ul>	<ul style="list-style-type: none"> <li>◇ 电池无破裂现象, 允许有漏液、变形及外观包装破裂现象。</li> <li>◇ It shall not explode during or at the end of a 1 hour short-circuit test. However, leakage of electrolyte, external deformation or outer sleeve cracking is permitted.</li> </ul>
19 安全阀启动性能 (过放电) Safety Valve Performance	<ul style="list-style-type: none"> <li>◇ 将电池以 0.2C 放电到 0V, 再将电流提高 1C, 放电 60min</li> <li>◇ The battery to 0.2C discharge to 0V, then raise the current 1.0C discharge 60min</li> </ul>	<ul style="list-style-type: none"> <li>◇ 安全阀必须正常启动, 电池无破裂现象, 允许有漏液、变形及外包装破裂现象。</li> <li>◇ The safety valve must start</li> </ul>

(Over dis-charging)		normally , battery without breakage;Leakage, distortion and outer package breakage are allowed
20 安全阀启动性能 (过充电) Safety Valve Performance (over charging)	<ul style="list-style-type: none"> <li>◇ 将电池以 0.5CmA 充电 5 小时。</li> <li>◇ to be charged with <u>0.5C</u> mA for 5 hours</li> </ul>	<ul style="list-style-type: none"> <li>◇ 电池无破裂现象，允许有漏液、变形及外包装破裂现象。</li> <li>◇ No explosion, but leakage, distortion and out package breakage are allowed</li> </ul>
21. 低温放电 To discharge at low temperature	<ul style="list-style-type: none"> <li>◇ 标准充电后，在 0°C±2°C 的温度条件下存放 24 小时，在环境温度 0°C±2°C，以 0.2CmA 的电流放电。</li> <li>◇ standard charged, to be stored for 24 hours at 0°C±2°C, and discharged at <u>0.2C</u> mA at 0°C±2°C</li> </ul>	<ul style="list-style-type: none"> <li>◇ 放电时间大于 4 小时。</li> <li>◇ Discharge duration shall exceed <u>4</u> hour</li> </ul>

**备注/Remark:**

**循环寿命/IEC Cycle life: IEC61951-2(2017)**

Cycles	Charge	rest	Discharge
1	0.1C×16hrs	0	0.25C×2hrs 20mins
2~48	0.25C×3hrs 10mins	0	0.25C×2hrs 20mins
49	0.25C×3hrs 10mins	0	0.25C to 6.0V/cell
50	0.1C×16hrs	1~4hrs	0.2C to 6.0V/cell

重复工步 1~50，直到任何第 50 工步放电时间小于 3 小时，测试终止。  
Cycl 1~50 shall be repeated until the discharge duration on any 50th cycle become less than 3hrs

**5. 运输、储存/The transportation and storage**

**5.1 运输/Transportation**

电池在运输过程中应保持在清洁、干燥、通风的环境，并防止剧烈振动、冲击或挤压，防止日晒雨淋，可使用汽车、火车、轮船和飞机等交通运输工具。

In the transportation process the battery should maintain at clean, dry, and the well ventilated environment, and prevents the fierce vibration, the impact or the extrusion, prevents to be exposed to the sun and rain. Battery could be transported by automobile, train, steamboat ,airplane and other transportation vehicle .

## 5.2 储存/Storage

5.2.1 储存的温度与湿度，电池应储存在环境温度为-20°C~35°C（以 15°C~25°C为宜），相对湿度不大于 85%的清洁、干燥、通风的室内，应避免与腐蚀性物质接触，应远离火源及热源。

Battery must be stored at -20 °C ~ +35 °C, (It is best at 15°C ~ +25 °C) and put in the clean, dry and ventilated place with relative humidity 85% max.. It must be kept away from corrodent substance, fire hazard and heat resource.

### 5.2.2 储存的放置方式/ Storage placement way

成箱电池堆放最高层数请勿超过五层，为保证电池箱之间有良好的空气流通状态，请保持纸箱间 5~10cm 以上距离，防止电池因堆积聚温而引起安全事故。

The packed battery in a carton stack less than 5 layers, to guarantee that between the cell box has the good air circulation condition, please maintain between the carton above 5~10 cm distance, which prevents the safety incident caused by a pile of agglomeration to heat .

## 6. 充电和放电曲线(单体)/ Charging and discharging curves(cell):

### 6-1. 充电曲线图/ Charging Curves

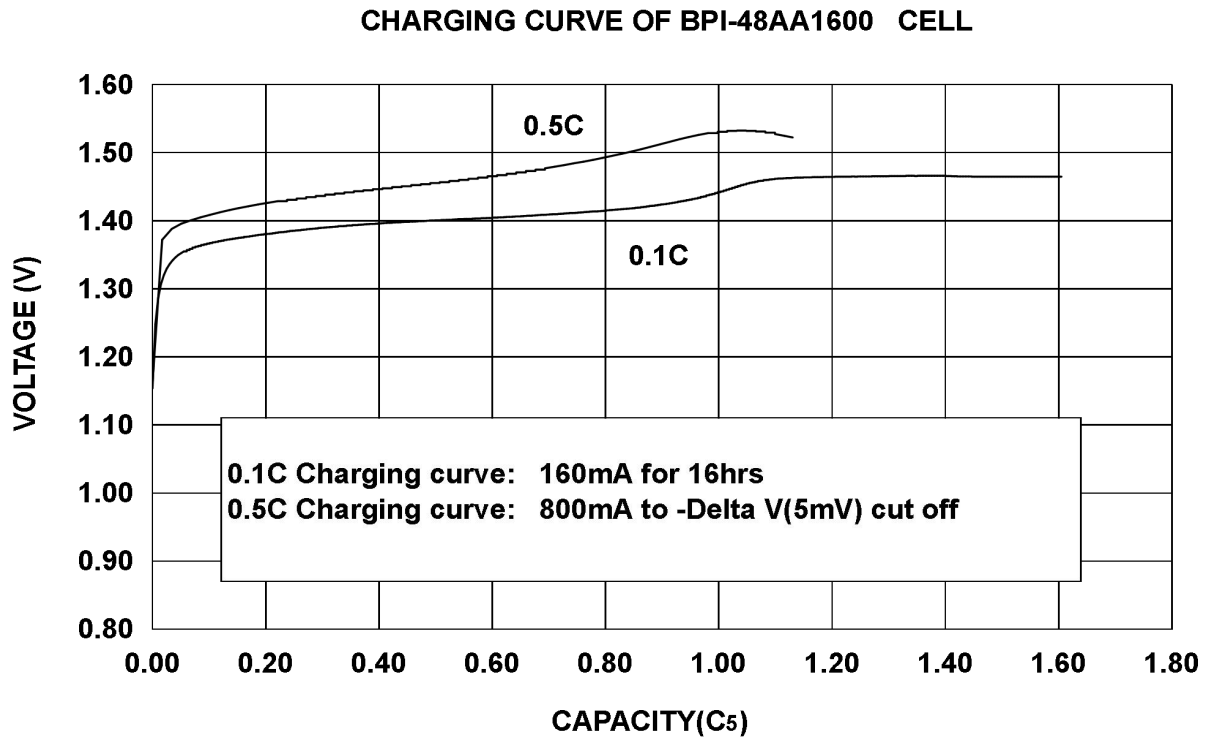

6-2. 放电曲线图/ Discharging Curves:

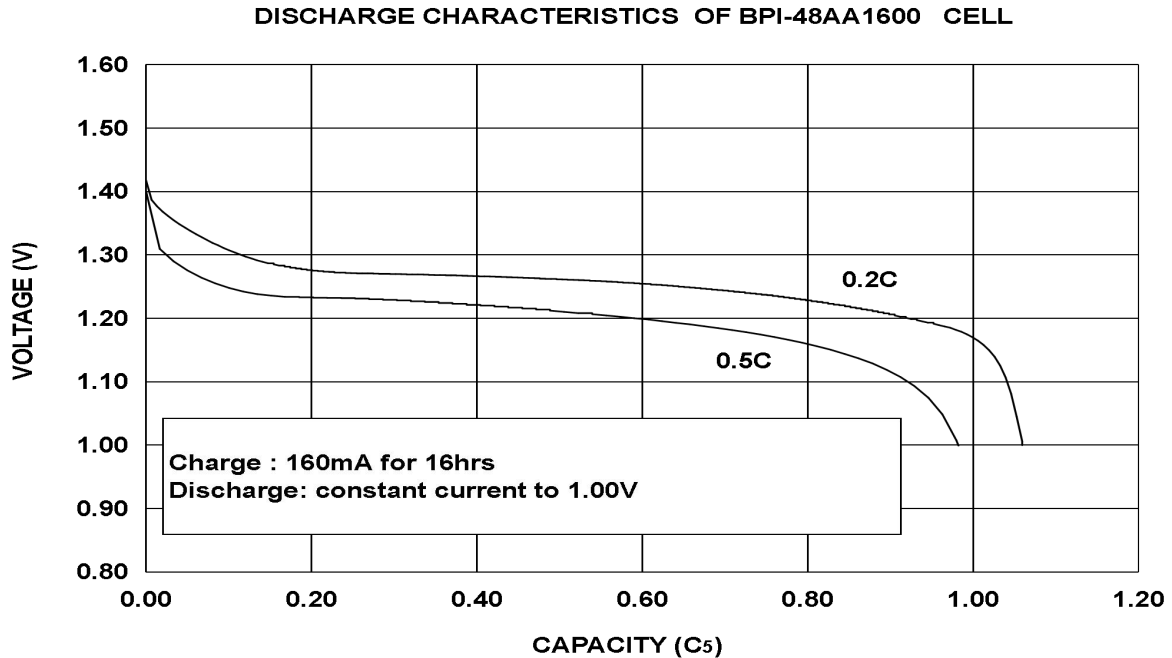

7. 警惕与防范/Warning and Security

为防止因电池影响造成设备故障，确保电路及电池配套使用安全。在设计和生产设备的时候，请充分考虑以下事项： To prevent the impact of equipment failure caused by the battery, and to make sure the security of circuit and battery set, please consider below things when design and produce the production equipment.

▲ 危险！！

★ 违反下述事项将会导致电池漏液、发热、爆炸、着火以及严重的人身伤害！

- (1) 禁止将 GMCELL 镍氢电池投入火中或加热！
- (2) 禁止将 GMCELL 镍氢电池用于碰撞或者投掷！
- (3) 勿将导线直接焊接在 GMCELL 电池上。
- (4) 勿将 GMCELL 镍氢电池放置于高于 1.5 米容易掉落的地方，勿使其从高于地面 1.5 米以上跌落。
- (5) 勿将 GMCELL 镍氢电池正负极用导电物，如导线等直接连接。如正负极引出片未套绝缘套，请勿运输或储藏，运输及储藏电池注意勿让金属项链、钥匙等导电物接触，运输或储藏请用专用器具（如专用纸箱）。
- (6) 须使用符合深圳市高巨能科技有限公司要求的指定充电器对 GMCELL 镍氢电池充电，并按深圳市高巨能科技有限公司的指示对电池充电。
- (7) 禁止拆开 GMCELL 镍氢电池。拆卸电池会引起外部或内部短路，导致暴露的电池成分在空气中发生化学反应，会导致发热、爆炸、着火，还会造成电池碱液的飞溅，非常危险。

**Danger !**

- (1)Against the following matters will result in battery leakage, heat, explosion, fire and serious personal injury!
- (2)Prohibited to throw the GMCELL battery into fire or heat!
- (3)Prohibited to collide or throw GMCELL battery!
- (4)Don't weld the lead on the GMCELL battery directly.
- (5)Don't put the GMCELL battery on a place which is more than 1.5 meter in case of dropping. Don't drop it at the height of more than 1.5 meter.
- (6)Don't connect the positive pole and electrode pole directly of GMCELL battery, such as leading wire. If the tab terminal of poles doesn't set insulation covering, please don't transport or store. Please don't touch the metal necklace, key or any other conductive material. Please use special carton when transport or store.
- (7)Must use the charger appointed by GMCELL to charge GMCELL batteries, and follow the instructors of GMCELL.
- (8)Prohibited to disassemble GMCELL batteries. It will cause external or internal short circuit, and the exposed parts will have chemical reaction then result in very dangerous heat, explosion, fire or splash of electrolyte.

**▲ 警告！！**

- (1) 勿将水、海水或其他的氧化试剂对电池进行处理，因这会引起电池生锈及发热。如果电池生锈，其减压防爆阀将不能工作，因而会导致爆炸。
- (2) 勿过充 GMCELL 镍氢电池，即不要超过充电器说明或指示的预设充电时间继续充电。如果 GMCELL 镍氢电池器预设充电时间充电后仍未满，请停止充电，延长充电时间将会导致电池漏液、发热及爆炸。
- (3) GMCELL 镍氢电池内含有无色强碱溶液（即电解液），如果皮肤或衣服与 GMCELL 镍氢电池电解液接触，请用硼酸水或醋酸水进行清洗后，用清水彻底冲洗。电池的电解液会腐蚀皮肤。
- (4) 禁止电池串联数量超过 20 支，因超过 20 支的电池串联会导致触电、漏液或发热。
- (5) 勿将电池外壳拆除，因这样会导致电池短路，引起漏液、发热、着火及爆炸。
- (6) 如 GMCELL 镍氢电池漏液、变色、变形或有其他变化，请停止使用，否则会导致发热、爆炸、着火。
- (7) 将 GMCELL 镍氢电池及其用电池驱动之电子产品放置于婴儿、小孩难以触摸的地方，以免出现误吞食电池之意外。如果发生意外，立即请医生处理。
- (8) 当 GMCELL 镍氢电池充满电后其使用时间远远少于其初始时的工作时间时，即该电池使用寿命已满，须换用另一新电池。

**Warning! !**

- (1) Don't contact batteries with water, sea water or other oxidation reagents, which will cause rustiness and heat. If batteries get rusty, explosive decompression valve won't work and will lead to explosion.
- (2) Don't over-charge GMCELL batteries, that is, don't continually charge batteries despite the designed charging time. If the batteries are not fully charged within the designed charging time, please stop to charge. The delay of charging time will lead to leakage, heat and explosion.
- (3) GMCELL NI-MH battery includes the colorless strong alkaline liquor (i.e. electrolyte), if the skin or clothes touch GMCELL NI-MH battery liquor, please use the boron acid water or the vinegar acid water to clean, after that , with the clear water thoroughly flushes. Because the battery's electrolyte can corrode the skin.
- (4) It is forbidden for more than 20 pcs batteries in series. Because it will result in leakage, getting shock or giving off heat.
- (5) Don't disassemble the battery, as it will result in short-circuit, leakage, giving off heat, catching fire and explosion.
- (6) Don't use the batteries when they are leakage, any color deterioration, distortion or other changes are found. Otherwise it will get hot, catching fire or explosion may happen.
- (7) Please keep the batteries and other electronic products related to battery away from baby, children, to avoid accident of swallowing of battery. If there is any accident, please go to see the doctor.
- (8) To use new battery when the working time of the battery is far short from the initial working time, as the cycle life of this battery is finished.

**8. 其他/ Others**

8.1 本公司保有对规格书修改的权利。

GMCELL reserve right to revise the specification;

8.2 未尽事宜由供求双方讨论决定。

Anything not mentioned in this specifications, customer and GMCELL should discuss to get a solution;

8.3 对未按规格书操作（人为导致短路烧坏）所造成的意外，本公司不承担任何责任。

GMCELL does not undertake any responsibility for the accidents caused by actions not matching with specifications(Man-made short circuit to burn out).

9. 附图/Drawings

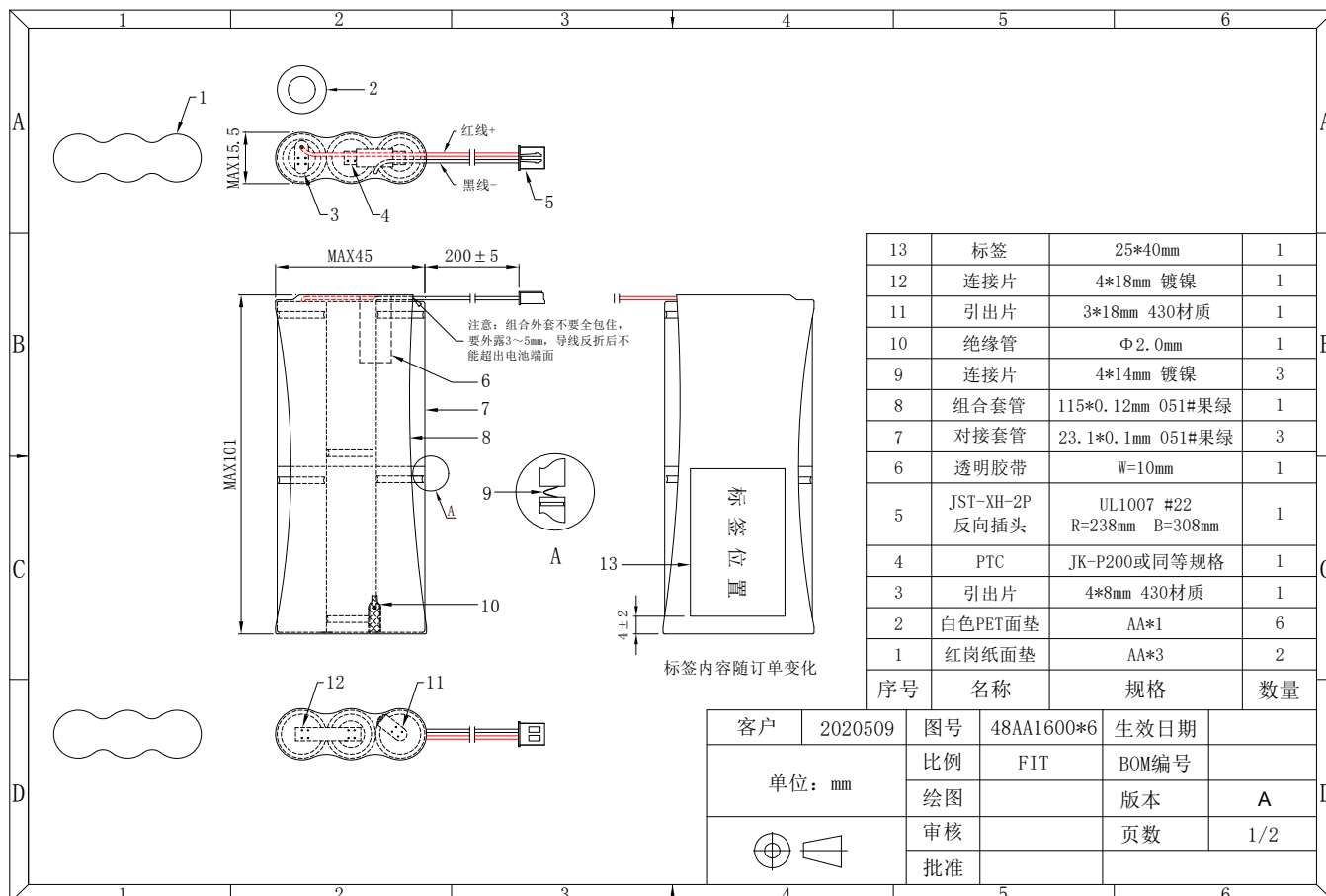

\*\*\*\*\* END \*\*\*\*\*