



Ni-MH BATTERY DELIVERY SPECIFICATIONS

镍氢电池规格书

PRESENTED TO (呈送): _____

MODEL NO. (产品型号): Ni-MH L9V-250mAh

DATE (制作日期): 2023/04/03

Customer Part No. (规格书编号): GMCELL-GC-025

The version number (版本号): 01

Specification Approved (规格书审批项)	Prepared By(编制)	
	Checked By(审核)	
Customer Approved (客户审批项)	Approved By(批准)	
	Please sign and return one copy to us. 请签名盖章确认后回传我司.	Seal the (盖章处)



1. Scope (适用范围)

This specification governs the performance of the following Nickel-Metal Hydride cylindrical battery.

本规格书适用于本公司下述型号的可充性镍氢电池组。

2. Model (型号): Ni-MH L9V--250mAh

3. External Appearance (外观)

The cell / battery shall be free from cracks, scars, breakage, rust, discoloration, leakage and deformation. 电池/电池组外观无破裂、划痕、变形、生锈、污迹、电解液泄漏等不良现象。

4. Ratings (规定参数)

The data involving the nominal voltage and the approximate weight of the battery pack. 此资料包括电池的额定电压和大约重量。

Description 种类	Unit 单位	Specification 规格	Conditions 条件
Nominal Voltage 标称电压	V	8.4V	
Rated Capacity 额定容量	mAh	250	Standard charging / discharging 标准充电/放电
Minimum Capacity 最小容量	mAh	250	Standard charging / discharging 标准充电/放电
Standard Charge 标准充电	mA	25(0.1C)	Ta 环境温度=0~45°C (see note)
	hour	16	
Fast Charge 快速充电	mA	125With charge termination control 用充电控制或保护	- $\Delta V=50\text{mv}/\text{PCS}$ Timer cutoff=110% input capacity Temp. cutoff= 40~50°C, Ta= 0~40°C dT / dt=0.6°C / min
	hour	2.4	
Trickle Charge 涓流充电	mA	7.5(0.03C)	Ta 环境温度=0~45°C (see note)
Discharge Cut-Off Voltage 闭路电压	V	7.0	Less than 1.0C discharge 小于 1C 放电
Maximum Continuous Discharge Current 最大连续放电电流	mA	500(2C)	Ta= -10~50°C 环境温度
Storage Temperature (Percent 40-60 charged state) 储存温度 (充电 40-60%)	°C	-20-50	Less than 30 days 储存时间少于 30 天
		-20-40	Less than 90 days 储存时间少于 90 天
		-20-30	Less than 360 days 储存时间少于 1 年
	%	65±20	Relative humidity 相对湿度
Typical Weight 重量	g	37.5	Approx. 大约



5. Performance (电池性能)

Unless otherwise stated, tests should be done within one month of delivery under the following conditions: 除非其它规定, 测试应在到货之日起 1 个月内进行, 并且符合以下测试条件:

Relative humidity (相对湿度): 65±20% RH.

Ambient Temperature (环境温度) (Ta) : $25 \pm 5^{\circ}\text{C}$ 。

***Notes: Standard charge / discharge condition (注意: 标准充电/放电条件)

Charge (充电) : $25\text{mA} (0.1\text{C}) \times 16 \text{ hrs}$, 30min (搁置) rest

Discharge (放电) : $50 \text{ mA} (0.2\text{C})$ to 7.0V

***The batteries must be standard discharged before charging (电池充电前必须先放电)。

***Battery test vide infra (电池测试参见下文) :

Test 测试项目	Unit 单位	Specification 规格	Conditions 条件	Remarks 备注
Capacity 容量	mAh	≥ 250	standard Charge / Discharge 标准充电/0.2C 放电	Up to 3 cycles Allowed 允许循环 3 次
Open Circuit Voltage (OCV) 开路 电压	V	≥ 9.0	Within 7 days after standard charge 电池标准充电后 7 天内	Unit: pcs 单位: PCS
Internal Impedance 交流内阻	mΩ	≤ 780	Upon fully charge (1Khz) 电池充满电后 (1Khz的交流频率)	Unit: pcs 单位: PCS
Discharge 放电 (0.2C)	min	≥ 300	standard charge, 30min rest before discharge at 0.2C to 7.0V 标准充电, 搁置 30 分钟后以 0.2C 放电至 7.0V	Up to 3 cycles Allowed 允许循环 3 次
Over charge 过充电	N/A	No leakage nor explosion 不漏液 不爆炸	0.1C charge for 48 H 用最大不超过 $25\text{mA} (0.1\text{C})$ 电流充电 48 小时	
Charged retention 荷电保持率	mAh	$\geq 187(75\%)$	Standard charge, storage for 1 year standard discharge at $20^{\circ}\text{C} \pm 2^{\circ}\text{C}$ 在 $20 \pm 2^{\circ}\text{C}$ 环境温度下标准充满电后存放 1 年, 以标 准 0.2C 放电至 7.0V	
	mAh	$\geq 162 (65\%)$	Standard charge, storage for 28 days, standard discharge at $60^{\circ}\text{C} \pm 2^{\circ}\text{C}$ 标准充满电后, 在 $45 \pm 2^{\circ}\text{C}$ 环境温度下存 7 天, 以标 准 0.2C 放电至 7.0V	
IEC Cycles Test 循环寿命测试	cycle 次	≥ 500	IEC 61951-2(2003) 7.4.1.1	
Short Circuit 短路测试	N/A	Deformatio & leakage may occur but no explosion 允许变形或漏液, 但不允许爆炸。	After standard charge, short circuit for 1 hr 引线(lead wire = $1.5\text{mm}^2 \times 20\text{mm}$) 标准充电方式充电后短路 1 个小时	
Vibration Test 振动测试 	N/A	$\Delta V < 0.70\text{V}$	Charge at 0.1C for 16 hrs, then leave for 24 hrs. Check battery before/after vibration. 0.1C 充电 16 小时后放置 24 小时, 检查电池振动前后的 电压。 Amplitude 振幅: 1.5mm , Vibration 振动: 3000CPM any direction for 60 mins 任意方向 60 分钟	

Drop Test 跌落测试	N/A	$\Delta V < 0.70V$	Charge at 0.1C for 16 hrs, then leave for 24 hrs. Check battery before / after drop on the wooden board of thickness: 30 mm Height: 50 cm Direction is not specified test for 3 times. 充电 16 小时后放置 24 小时后, 电池从 50cm 高度任意方向自由坠落到厚 30mm 的木板上 3 次。
-------------------	-----	--------------------	--

6. Warranty (保证)

One year limited warranty against workmanship and material defect.
我们对工艺和材料的保证期限为 1 年。

7. Cautions (使用注意事项)

1. Reverse charging is not acceptable.
应将电池极性正确连接, 不可反接。
2. Charge before use, use the correct charger for Ni-MH batteries.
使用之前请充电, 请使用 Ni-MH 专用充电器。
3. Do not charge / discharge with more than the specified current.
请不要超过规格要求电流对电池/电池组进行充放电。
4. Do not short circuit the cell / battery.
请不要将电池/电池组短路。
5. Do not incinerate or mutilate the cell/battery.
请不要将电池/电池组投入火中或试图拆开。
6. Do not solder directly to the cell / battery.
请不要在电池/电池组上直接焊锡。
7. The life expectancy may be reduced if the cell / battery is subjected to adverse conditions, like extreme temperature, deep cycling, excessive overcharge /over-discharge.
如果电池/电池组在极限条件下使用, 可能减少寿命:
如: 极限温度, 深度循环, 过充电或过放电。
8. Store the cell / battery in a cool dry place.
电池/电池组应储存在阴凉干燥处。
9. For charging methods please reference to our technical handbook.
充电方法请参考我们的技术手册。
10. When find battery power down during use, please switch off the device to avoid overdischarge.
电池使用时发现功率下降, 请关闭用电器开关以防止电池过放。
11. When not using a battery, disconnect it from the device.
当电池不使用时, 请把它从装置上取下。
12. well-ventilated place out of direct sunlight.
电池使用后, 如果电池发热, 再次充电前, 请在通风环境中冷却。
13. During long term storage, battery should be charged and discharged once every half a year.
经过长时间存放, 电池应每三个月进行一次充放电。
14. When the battery is hot, please do not touch it and handle it, until it has cooled down.
如果电池发烫, 请勿触摸, 直至冷却。
15. Do not mix batteries with other battery brands or batteries of a different chemistry such as alkaline and zinc carbon batteries.
请不要将电池与其他品牌的电池或者不同种类的电池, 比如碱性锌电池混用。
16. Do not mix new batteries in use with semi-used batteries, battery may be over-discharged.

请不要将新旧电池混用,可能会导致过放电。

17. Do not mix new batteries in use with semi-used batteries, battery may be over-discharged.

请不要尝试分离、挤压、撞击电池,电池会发热或起火。电池中的碱液对皮肤、衣服和眼睛有害,而且会损伤衣服。

18. Keep away from children. If swallowed, contact a physician at once.

放在儿童拿不到的地方,如果发现吞食,请立即联系医生。

8.Specifications of single cell (单粒电池规格)

Dimensions 外形尺寸(mm)

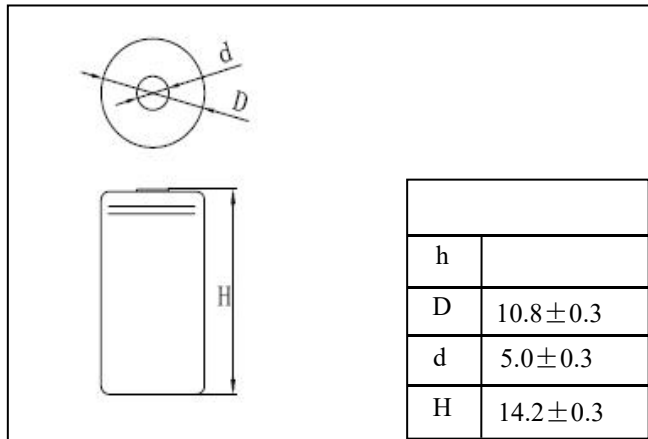

Nominal Voltage 标称电压: 1.2V

Rated Capacity 额定容量: 250 mAh

Minimal Capacity 最小容量: 250mAh

Standard Charge 标准充电: 25mA, 16hrs

Rapid Charge 快速充电: 125 mA, 2.4 hrs (control required)

Continuous Discharge 连续放电: less than 500mA

Final Discharge Voltage 放电终止压: 1.0V

Weight 重量: 4.9g (Approx)

Service Life 循环寿命: (>500cycles)

(according to IEC discharge characteristics standard)

根据 IEC 标准测试

Internal Resistance 内阻: ≤90mΩ

Ambient Temperature 周边温度:

Standard charge 标准充电: 0 ~45°C

Rapid charge 快速充电: 0 ~40°C

Discharge 放电: -20 ~ 50°C

Store(贮存): (65±20% RH)

Less than 30 days(少于 30 天): -20 ~50°C

Less than 90 days(少于 90 天): -20 ~40°C

Less than 360 days(少于 1 年): -20 ~30°C

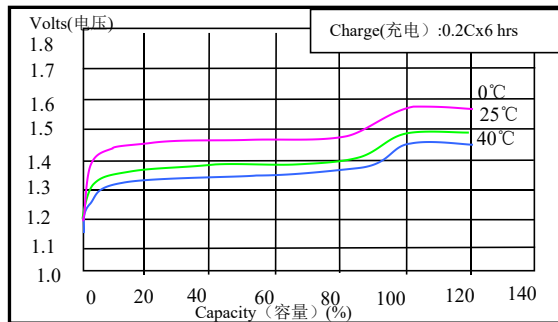

0.2C Rate Charging Curves (充电曲线图)

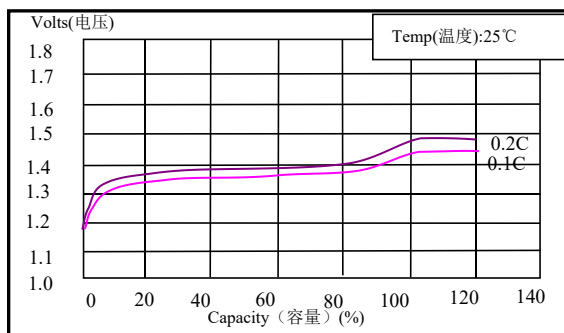

0.1C/0.2C Rate Charging Curves(充电曲线图)

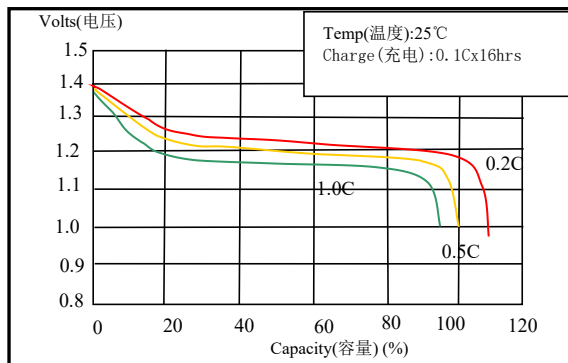

0.1C/0.5C/1.0C Rate Discharging Curves(放电曲线图)

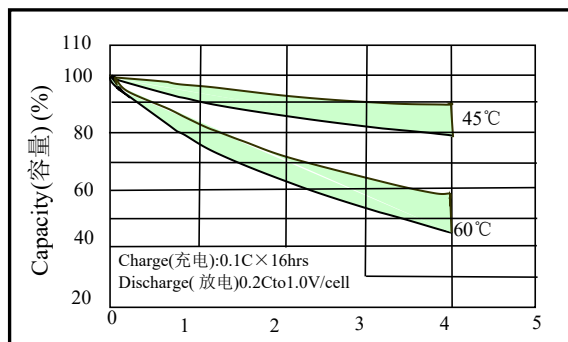

Storage & self discharge Curves
不同温度荷电保持曲线图

